

# The Paper Beverage Carton: Past and Future

This history of the paperboard beverage carton, emphasizing recent developments culminating in development of a paper carton replacement for the metal can, demonstrates how the various advances over the years were heavily dependent on available technologies.

Gordon L. Robertson

**T**he need to carry liquids is as old as mankind. In the beginning, skins and shells were used. These were followed by ceramics and glass and, more recently, metals. In the 20th century, two new materials emerged: paperboard and plastics. At first, the idea of carrying liquids in a form of paper seemed unconvincing, yet it has proved highly efficient and, because it is made largely from a renewable resource, meets the ecological challenges of the 21st century better than any of its competitors. Today, paper beverage cartons are available in a wide variety of sizes and shapes (Fig. 1).

This article will review the history of the paper beverage carton and emphasize recent developments that make the carton even more useful to the food and beverage industries—and the consumer—today and will continue to do so in the future.

## Developments in the United States

The first records of paper being used to carry liquids on a commercial scale are found in reports, dated 1908, of a Dr. Winslow of Seattle. He remarked on paper milk containers which were invented and sold in San Francisco and Los Angeles by a G.W. Maxwell as early as 1906. Paraffin wax was used to moisture-proof the paper, but achieving a liquid-tight bond at the joins was more difficult. Because the adhesive came into contact with the contents, difficulties were encountered in avoiding contamination and taint problems, even when using animal-based products.

In 1915, John Van Wormer of Toledo, Ohio, was granted a United States patent for a “paper bottle” (actually a folded blank box) for milk that he called *Pure-Pak* (Fig. 2). The crucial and unique feature was that this box would be delivered flat to be folded, glued, filled, and sealed at the dairy. This offered significant savings in delivery and storage compared to preformed glass bottles, then the predominant package for milk, having been introduced in 1889. The challenge came with the de-

The author, a Professional Member of IFT, is Vice President, Environmental and External Affairs, Tetra Pak Asia & Americas, 19 Gul Lane, Singapore 629414.



Fig. 1—Some of the paper beverage cartons available today. The Tetra Classic carton is shown at the left; the Tetra Top cartons with injection molded polyethylene tops made in the filling machine are shown on the right; and the Tetra Fino Aseptic paper pouch is shown in the foreground.

sign of the machinery to be sold or leased to the dairy to form, fill, and seal the cartons.

The shortage of tinplate for steel cans during World War I greatly increased the use of paper containers in marketing various food products, including cottage cheese (and other soft curd cheeses) and malted milk (Anonymous, 1918).

In 1928, the American Paper Bottle Co. acquired the Van Wormer patents and the Pure-Pak trademark. It built the first six machines from 1929 to 1934, while striving to perfect both the container and machinery. In the early 1930s, it promoted its Pure-Pak milk containers to dairies and consumers. Articles in publications such as *Modern Packaging* and *Popular Science Monthly* described forming the box, gluing the base, and dipping the carton in hot paraffin wax to moisture-proof both the inside and outside. The carton was then filled and the top closed by folding, squeezing under heat, and stapling to achieve a total seal. A range of carton sizes was mentioned, from half-pint to a quart (about 240 mL to 950 mL).

By the 1930s, some ten companies had introduced some kind of paper

package for milk in the U.S. For example, *Sealcone* (cone-shaped) containers were introduced in New York in 1929 and were given a glowing two-page write-up in *Scientific American* (Anonymous, 1929). Among the advantages listed were that it was lightweight (1½ oz for a quart container), leakproof, and tight and gave the milk “which comes in a completely sterile condition” a long shelf life. Just how the containers were sealed is not clear, but they were opened “quite simply by cutting off the narrow end of the cone—a scissors will do.”

Other brand names included American Can Co.’s *Canco* package and Sealright’s *Megaphone*, but most were short-lived. An interesting description of the ease of opening and closing the Reed paper milk bottle was carried by *Scientific American* (Anonymous, 1934): “To open this container, you simply raise the metal top, press back two of the wings, and compress them to form a spout. The container is closed by simply pressing back the spout and replacing the metal clip, which keeps the container tightly closed. This new kind of spout never leaks or drips, and it pours as easily as the spout of a

cream pitcher. As it is made of paper, it eliminates the need of picking up empties, bringing them back, inspecting and washing them. Moreover, it does away with bulk, weight, breakage, and waste, and effects a tremendous reduction in bottling costs.”

In 1934, American Paper Bottle Co. approached Ex-Cell-O Corp. to manufacture machines to form, fill, and seal Pure-Pak cartons. Six prototypes were commissioned, but funds ran out, and Ex-Cell-O took over the rights to the Pure-Pak system as part of the settlement. Ex-Cell-O promptly began to redesign both the machinery and the package.

The first Ex-Cell-O Pure-Pak filling machines were installed in 1936 at Borden’s Dairies, New York, N.Y., producing 24 quart cartons/min, then at Risdon Bros, Detroit, in early 1937. The construction principle was the same as Van Wormer’s original, with the carton formed from a blank, glued at the bottom, dipped in paraffin wax, and filled and the top folded and stapled shut. These early versions had to be opened with a knife or scissors. Ex-Cell-O quickly redesigned the top with a tab on the side of the gable that could be lifted for pouring.

The glass bottle had long been the accepted milk package, and the dairy industry was understandably reluctant to change. Handling equipment was all

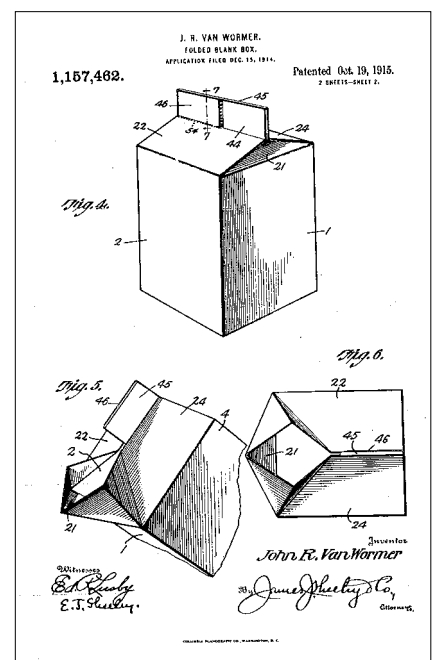

Fig. 2—First patent for the gable-top carton, filed by John Van Wormer in 1915.

# The Paper Beverage Carton: Past and Future

designed for bottles, not cartons. Federal, state, and local health codes and weights-and-measures regulations posed similar problems, since most had been adopted before the invention of the carton. A typical state law of the time read “a milk bottle will be considered full when the top surface of the milk is within one-eighth inch of the bottom surface of the cap or stopple.” Lacking a cap or stopper, the paper carton obviously could not comply, so reg-

ulations like this had to be changed state by state, county by county.

One of the longest and most expensive struggles took place in Chicago, Ill., where the city board of health blocked the sale of Pure-Pak cartons with an 1888 ordinance which read, “All milk sold in quantities of less than one gallon (3.85 liters) must be in a standard milk bottle.” It took six years and cost more than \$500,000 to have the four words “or other approved container” added to the ordinance!

Dairies preferred bottles because they effectively created a monopoly where they established their collection system. Cartons extended the range beyond the 20–30 miles over which a dairy could operate effectively with bottles; enterprising companies saw the potential and moved to cartons. In 1937, the first full year for Pure-Pak cartons on the market, the company sold 42 million cartons. Pure-Pak’s unique selling point was the fact that the packages were delivered flat, thus saving storage and transport costs. Once filled, they also weighed considerably less than glass bottles of milk.

Shortages of paperboard, paraffin wax, and staples presented new challenges, particularly during and immediately following World War II. Half-pint and half-gallon cartons joined the pint and quart sizes in 1948, with the half-gallon destined to become the industry standard. In 1955, the “Pitcher Pour” built-in pouring spout replaced the perforated tabs and openings covered by paper patches. It was made possible by the development of an antiseptic or “adhesive” which allowed the carton top to be tightly sealed but easily opened.

Another breakthrough came in 1963 with the large-scale introduction of the gallon carton. Paralleling all the above were significant and continuous developments by the pulp and paper industry to provide solid bleached sulfate (SBS) paperboard from which to make the cartons and the development of high-speed rotary converting equipment to produce precision-cut and creased blanks.

## Developments in Europe

Jagenberg Werke AG, in Dusseldorf, Germany, was the first European company to follow the American trend. Having during World War I developed a leak-proof paper “can” for marm-

lade consisting of a seamed carton base and a similar lid, the company applied for a patent for its *Perga* pack in 1929 in England and one year later in Germany.

The Perga carton was made of ribbed and paraffin-coated paper sleeves and had a circular base with a square top. In contrast to the U.S. development, however, this carton was oriented not toward high-speed machines but rather toward the many hundreds of dairies and filling plants that wanted to fill their products into cartons without considerable investment.

Production of the Perga milk carton with a capacity of 200 mL began in 1932. By 1939, 26 Perga production companies had been set up in eight countries, including Germany, England, the U.S., Sweden, Canada, and Australia. Although the economic and political crisis of the following years initially supported ongoing development and distribution of the new carton, it finally put a stop to it.

Other European moves began around this time. Erling Stockhausen in Norway developed a paper milk carton together with filling equipment that went into trial production in a dairy in southern Norway during 1939 and 1940. The arrival of World War II stopped further work.

In the early 1950s, the Perga pack enjoyed a renaissance. By the '60s, it was not only one of the most widely used cartons on the European market but also an expression of the new way of life. Once again, political decisions played a role in technical development. Since many wells and water pipes had been destroyed during World War II, it was very difficult to maintain sterile conditions in dairies, and this led to the politically favored changeover from the glass bottle to the Perga pack.

In line with its growing share of the market, Jagenberg Werke founded its subsidiary Papier und Klebstoffwerke Linnich (PKL) GmbH in 1958. PKL is currently owned by Schweizerische Industriegesellschaft (Swiss Industrial Co.) in Neuhausen, Switzerland, and is called SIG Combibloc.

## Tetrahedral Carton

In 1920 in Sweden, Ruben Rausing, impressed with the fresh approaches then being developed in distribution and retailing, especially self-service

## Consumers in 1935 preferred glass

A minor industrial battle is brewing between the glass milk bottle and the paper milk bottle. Manufacturers of the paper containers have been pecking at a few eastern markets for several years. For paper containers the claims are that they are more sanitary and more easily handled—permitting milk sold in them to be distributed at less cost and sold at lower price. On the side of glass is the argument that it is just as cheap, that it affords visibility of the contents and of the “cream line,” that the returnable bottle can be made perfectly sterile, and—its strongest defense—that it is entrenched in the housewife’s heart and habits. Whatever the merits of these arguments, here is evidence of the preference to be conquered if paper is to win its place:

Would you rather have your milk delivered in a glass bottle, a paper container, or a tin can:

|                 |       |
|-----------------|-------|
| Glass bottle    | 88.2% |
| Paper container | 6.0   |
| Tin can         | 1.0   |
| Don’t care      | 4.5   |
| Don’t know      | 0.3   |

But the cause of paper is not hopeless, because 63 per cent of the 6.0 per cent who favored it come from six of the few places where it has definitely been tried out—and the rest are scattered throughout the land among people willing to accept anything new. The objection to paper most frequently volunteered was that it was “less sanitary”—a belief that could be eliminated through education.

*From Fortune magazine, October 1935, p. 176. Survey based on 3,000 interviews.*

# The Paper Beverage Carton: Past and Future

stores, in the U.S., realized that this trend would come to Europe and would increase the demand for pre-packaged goods.

By the early 1930s, he was the sole owner of Åkerlund & Rausing, a pioneering Swedish packaging company that enabled the prepackaging of consumer units of flour, sugar, and salt, which until then had been packaged at the retail outlet immediately prior to purchase. In 1943, development work commenced on a milk package to “give maximum hygiene with minimum material.” The company evaluated the gable-top cartons then being introduced in the U.S. for milk but judged that the cartons and the associated packaging machinery were too expensive to be commercially viable in Sweden.

Because of a shortage of glass and tinfoil during World War II, Åkerlund & Rausing developed *Satello*, a wax-coated, cylindrical paper container for jam and similar products (Leander, 1996). This was the starting point for the development of a milk package continuously formed from a reel of packaging material, a patent being applied for in March 1944 (Rausing, 1944). This package was achieved by the simple technique of sealing and cutting a tube of moisture-proofed paperboard at alternate right angles, leading to the tetrahedron-shaped carton which gave the resultant company its name, Tetra Pak.

Then began the long development process to find a way of automatically shaping, filling, and sealing the package, together with a search for suitable packaging material. By May 1946, a simple prototype filling machine from bicycle chains and cogwheels with wooden sealing jaws attached had been built (Fig. 3). In 1950, the name *Tetra Pak* was registered. Today, Tetra Pak is the leading supplier of processing and packaging equipment and materials to the global liquid food industry.

While development of a filling machine was underway, the search for a suitable packaging material continued. A dispersion coating of polyvinyl chloride was tried and rejected. A polystyrene mixture known as S-50 was then tried and proved satisfactory and was used successfully on the first packages. In 1952, the first commercial machine from Tetra Pak to make tetrahedral cartons was delivered to the Lundaortens Mejeriforening dairy in Lund, Sweden.

Packing of cream in 100-mL cartons began in November, and during the next 12 months several other Swedish dairies installed Tetra Pak systems. The following year saw the first export to Germany.

At that time, commercial production of low-density polyethylene (LDPE) film from ICI was increasing, and Du Pont in the U.S. had acquired a manufacturing license. Du Pont developed an extrusion coater in 1954, and Tetra Pak began coating paperboard with polyethylene in 1956.

## Gable-Top Carton

After World War II, Pure-Pak cartons arrived in Europe to supply the U.S. troops stationed in Germany. Their demand for milk meant that it was imported from Austria, Denmark, France, Italy, and the Netherlands, in cartons supplied from the U.S.

By 1957, Pure-Pak had 60% of the U.S. milk market. The Norwegian company Tiedemanns obtained a license from Pure-Pak, partly to help supply cartons for the U.S. troops in Germany and partly in the belief that the European market was now ready and could afford such a package. The company became known as Elopak (from *European Licensee of Pure-Pak*), and its first customer was the Netherlands dairy Sterovita, which committed itself to 40–50 million “blanks” annually. Establishing Elopak required great belief in the potential of beverage cartons because the Norwegian dairy industry had just converted from clear to colored (brown) glass and was not eager to make further changes. Even so, in 1958 the first milk in Pure-Pak cartons went on sale by Asker Dairy outside Oslo, Norway, and was promptly a big success, despite a premium price compared to bottled milk.

In 1959, after a research and development project of several years, Ex-Cell-O converted all 5,000 of its machines to coat paperboard with polyethylene, rather than moisture-proof with wax. Elopak also switched to polyethylene-coated boards, and the first supplier it could find in Europe for suitable paperboard was Enzo-Gutzeit in Imatra, Finland, now one of the world’s major producers of paperboard for beverage cartons as part of the Swedish-Finnish conglomerate Stora-Enso.

In 1966, Tetra Pak began offering its

own gable-top machines and cartons known as *Tetra Rex* on the basis of a license agreement with interested parties in the U.S. (Leander, 1996).

By the early 1970s, more than half of the fluid milk in the U.S. was packaged in half-gallon Pure-Pak cartons, with another 20% in gallon cartons. In terms of number of cartons sold, today’s favorite is the half-pint carton, in large part because of its popularity in school breakfast and lunch programs. Since 1974, the carton’s economy and handling advantages have been further enhanced by a small-cross-section version. Slant-top and flat-top styles have joined the conventional gable-top, and a variety of opening and resealing devices have been introduced.

An innovative package consisting of a traditional plastic-coated paperboard base but with an in-line-injected LDPE top heat-sealed to the carton walls was released by Tetra Pak in 1983 under the name *Tetra Top*. Now available in sizes ranging from 200 mL to 1.5 L and with a variety of pull-tab and screw-top openings, it is positioned at the premium end of the pasteurized product market.

Since 1985 Elopak has been the licensed sales agent for Shikoku, a Japanese manufacturer of gable-top packaging systems (Nermark 1999). In 1987, Elopak acquired Ex-Cell-O’s Packaging Systems Division and became the owner of the Pure-Pak license worldwide.

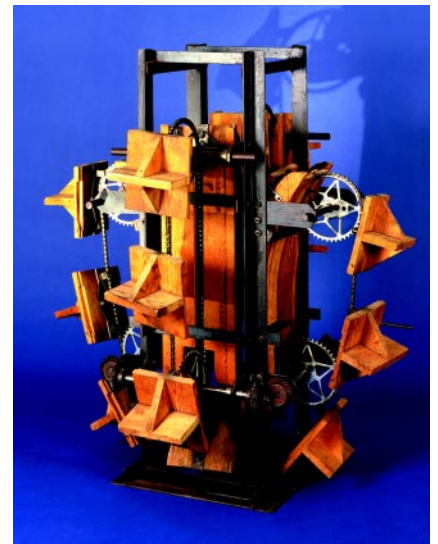

Fig. 3—Simple prototype filling machine constructed from bicycle chains and cogwheels with wooden sealing jaws attached, built by Tetra Pak in 1946.

## Brick-Shaped Carton

Although the starting point was initially a practical package for small fillers, the market now needed a more-sophisticated carton which would be easy to transport even unfilled. In 1956, PKL (now Combibloc) patented a brick-shaped *Blockpak* system of packages and filling machines and replaced paraffin wax moisture-proofing with a polyethylene extrusion coating. Its dimensions were based on binding European pallet dimensions, and like the gable-top carton it was a blank-fed system available in capacities up to 2 L. It gained wide acceptance and leadership, particularly in Germany, Austria, and the UK during the 1960s and '70s and provided stiff competition to the gable-top carton. Today it is no more, having been replaced in 1979 by the *Quadrobloc* gable-top package.

In 1963, Tetra Pak commercially released the rectangular, brick-shaped package which was patented as *Tetra Brik*, following a development program begun in 1959. Unlike the gable-top carton but in keeping with the original tetrahedral carton, it was a reel-fed rather than a blank-fed system. The dimensions of the Tetra Brik are also compatible with international conventions for pallets used in transport and storage.

## Aseptic Cartons

The Fellows of the Institute of Food Technologists, in connection with the society's 50th anniversary celebration in 1989, ranked aseptic processing and packaging as "the most significant food science innovation of the past 50 years."

Aseptic packaging can be defined as the filling of a commercially sterile product into sterile containers under aseptic conditions and sealing of the containers so that reinfection is prevented, i.e., so that they are hermetically sealed. The term "aseptic" implies the absence or exclusion of any unwanted organisms from the product, package, or other specific areas, while the term "hermetic" (airtight) is used to indicate suitable mechanical properties to exclude the passage of microorganisms into a package and gas or water vapor into or out of the package. The term "commercially sterile" has been defined as the absence of microorganisms capable of reproducing in the food under nonrefrigerated conditions of storage

and distribution, thus implying that the absolute absence of all microorganisms need not be achieved (Robertson, 2002).

The first aseptic packaging of food (specifically milk in metal cans) was carried out in Denmark by Nielsen prior to 1913, and a patent for this process (termed aseptic conservation) was granted in 1921. In 1917, Dunkley in the U.S. patented sterilization with saturated steam of cans and lids and subsequent filling of a presterilized product. In 1923, aseptically packaged milk from South Africa reached a trade fair in London, England, in perfect condition. American Can Co. developed a filling machine in 1933 called the Heat-Cool-Fill (HCF) system, which used saturated steam under pressure to sterilize the cans and ends.

In the 1940s, Martin developed a process in which empty metal cans were sterilized by treatment with superheated steam at 210°C prior to being filled with cold, sterile product. In 1950, the Dole company bought the first commercial aseptic filling plant on the market (Robertson, 1993).

At the end of the 1940s, a dairy enterprise (Alpura AG, Bern) and machinery manufacturer (Sulzer AG, Winterthur) in Switzerland combined to develop ultra-high-temperature-sterilized, aseptically canned milk which was marketed in Switzerland in 1953. However, this system was not economic, mainly because of the cost of the cans, and Alpura, in collaboration with Tetra Pak, began developing an aseptic cartoning system in 1957. As early as the mid-1950s, Tetra Pak had started a technological collaboration with the Swiss industrial group Ursina for the development of long-shelf-life milk products.

The first Tetra Pak machine for aseptically filling sterilized cartons with sterilized milk was installed in a dairy in Thun, Switzerland, and milk packaged in this manner was first sold in Switzerland in October 1961. The tetrahedral cartons were made with an added layer of thin (9-micron) aluminum to give the required protection, enabling the milk to be kept for up to 6 months without the need for refrigeration.

The aseptic carton normally consists of layers of bleached and unbleached paperboard coated internally and externally with polyethylene, resulting in

a carton which is impermeable to liquids and in which the internal and external surfaces may be heat sealed. There is also a thin layer of aluminum foil which acts as a gas and light barrier (Fig. 4).

The outer polyethylene layer protects the ink layer and enables the package flaps to be sealed. The bleached paperboard serves as a carrier of the decor and gives the package the required mechanical rigidity. The laminated polyethylene binds the aluminum to the paperboard. The aluminum foil acts as a gas barrier and provides protection of the product from light. And the two inner polyethylene layers provide a liquid barrier and enable the carton to be heat sealed (Robertson, 1993).

The most significant development in the history of the aseptic carton was the commercial release in 1969 of the *Tetra Brik Aseptic* carton. This packaging system now accounts for more than 80% of the company's packages and dominates the aseptic beverage carton market. In May 1975, the first Combibloc aseptic system was presented to the packaging world, differing from the Tetra Brik Aseptic in being a blank-fed system.

International Paper, the giant forestry and packaging company, recognized the opportunity for a complete packaging line and, since 1981 has offered its customers not only the supply of blanks but also form-fill-seal (FFS) machines, following the acquisition of Systempack in Europe in 1981 and the Cherry-Burrell Packaging Div. in 1991. They are now being marketed as a web-fed aseptic pack-

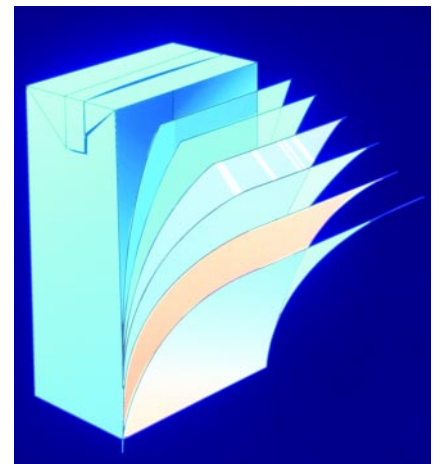

Fig. 4—Structure of the Tetra Brik Aseptic carton. The layers, from outside to inside, are polyethylene, paper, polyethylene, aluminum foil, polyethylene, and polyethylene.

# The Paper Beverage Carton: Past and Future



Fig. 5—The Tetra Recart retortable paper carton, which provides a shelf life of 18 mo.



Fig. 6—The octagonal-shaped Tetra Prisma Aseptic carton.

aging system and as a blank-fed gable-top system, with packaging materials supplied from International Paper's own manufacturing plants in different parts of the world. More recently, International Paper became the sales agent for the Fuji aseptic packaging system developed by the Japanese company Shikoku, with machines and packages similar to the Tetra Brik Aseptic system.

Throughout the 1970s and '80s, beverage carton manufacturers and their customers continued to develop cartons with different shapes and sizes and convenient add-ons such as drinking straws, screw caps, and reclosures. At the same time, through the advent of the aseptic carton, there was a rapid increase in the range of liquids packaged in cartons, from milk, cream, and juices at the beginning of this period to soups, sauces, waters, wines, teas, and many other products by the late '80s. The *Tetra Fino Aseptic* paper pouch was launched in 1997 and is enjoying rapid growth in various countries, including China, India, and Egypt.

## Environmental Aspects

As noted above, early promoters of beverage cartons stressed their disposability as one of their key advantages. However, changes in political and public attitudes through the 1980s saw packaging come under scrutiny in ecological terms, and beverage cartons were subjected to life-cycle analyses (LCAs) in comparison with alternatives such as plastic containers and returnable glass bottles. In Germany, where the environmental scrutiny of packaging has been most intense, an LCA undertaken for the Environment Ministry concluded that there were essentially no significant differences in environmental

impacts between the reusable glass milk bottle and the one-way milk carton. The combination of being manufactured largely from a sustainable, renewable resource, suitability to all waste-management options, and a highly efficient logistics performance, together with their intrinsic convenience and safety, is ensuring that the beverage carton has an excellent future.

Today, recycling of beverage cartons is also common in many countries. The major method is repulping, enabling the virgin paper fibers to be recovered and reused, with the polyethylene/foil rejects being further processed or used as fuel in boilers. An alternative process developed by Tetra Pak is to shred the used cartons and heat them under pressure to form particle board, which can then be used for such things as furniture, wall linings, and form work for concrete.

## Future Developments

The most recent and arguably the most exciting development for the paperboard carton was the field testing by Tetra Pak in 2001 of *Tetra Recart* (Fig. 5), a blank-fed, retortable square-shaped carton for soups, ready meals, vegetables, and pet food. Developed as a replacement for the metal can, it is expected to be released commercially in 2003. Of basically similar structure to the aseptic carton but with polypropylene replacing polyethylene, products packaged in it have a shelf life under ambient conditions of 18 months.

Despite predictions to the contrary, beverage paper cartons continue to increase in sales worldwide, and they can now be found in more than 170 countries. While the pasteurized milk market in countries such as the U.S., UK, and Australia has seen a decline in gable-top cartons

with a concomitant increase in large-sized HDPE plastic bottles, the aseptic carton market is growing rapidly, especially in developing countries such as Brazil, Mexico, and China.

Future developments will focus on several key areas. First, the range and functionality of opening and closing devices applied to cartons to enhance consumer convenience will increase. Second, there will continue to be new and exciting shapes and contours, building on the success of the octagonal-shaped *Tetra Prisma* carton released in 1996 (Fig. 6). Third, the range of barrier plastics used will increase, and as a result it is likely that the use of aluminum foil as a barrier will decline. The absence of aluminum then opens the door to microwavable cartons for products such as tea, coffee, and soups.

## REFERENCES

- Anonymous. 1918. Fiber containers as a substitute for glass and tin. *Sci. Am.* 118: 59.
- Anonymous. 1929. Paper milk bottles. *Sci. Am.* 140: 332.
- Anonymous. 1934. New paper milk bottle. *Sci. Am.* 151: 50.
- Leander, L. 1996. "A Vision Becomes Reality." Tetra Pak Intl. SA, Pully, Switzerland.
- Nermark, C. 1999. Packaging of beverages in drinks cartons. Chpt. 8 in "Handbook of Beverage Packaging," ed. G.A. Giles. CRC Press, Boca Raton, Fla.
- Robertson, G.L. 1993. Aseptic packaging. Chpt. 13 in "Food Packaging: Principles and Practice." Marcel Dekker Inc., New York.
- Robertson, G.L. 2002. Ultra-high temperature treatment (UHT) (b) Aseptic packaging. In "Encyclopedia of Dairy Sciences," ed. H. Roginski, J.W. Fuquay, and P.F. Fox. Academic Press, London.
- Rausing, R. 1944. Way of producing a tetrahedral-shaped package plus the package produced in this manner. Swedish patent 131,599.
- Van Wormer, J.R. 1915. Folded blank box. U.S. patent 1,157,462. ●