

Engine Compartment Inspection

Unit Contents

	Student Page	
Student Components	Learning Activities Sheet 7-3	
	Abbreviated Checklist 7-5	
	Objective Sheet 7-7	
	Expanded Checklist 7-9	
	* Job Sheets	
	1—Inspect and Adjust Drive Belts and Tensioners 119	
	2—Take Oil Sample, and Change Oil and Filter(s) 123	
	3—Inspect Engine Coolant Level and Condition 127	
	4—Pressure Test Coolant System and Radiator Cap 131	
	5—Make a Charging System Output Test; Determine Needed Repairs 135	
6—Perform an Engine Compartment Inspection 139		

* The Jobs Sheets are located in the Student Workbook.

Engine Compartment Inspection

Prerequisites:
None

Learning Activities Sheet

Student Name _____

Place a checkmark in the appropriate box as you complete each of the steps below.



- 1. **Read** Objective Sheet.
- 2. **Study** Expanded Checklist, “Engine Off” Task 1.
- 3. **Do** Job Sheet 1, “Inspect and Adjust Drive Belts and Tensioners.”
- 4. **Stop** Have instructor evaluate your performance and if the evaluation is satisfactory, continue to Step 5. If the evaluation is not satisfactory, study the procedure outlined in Job Sheet 1 and repeat Step 3.
- 5. **Study** Expanded Checklist, “Engine Off” Tasks 2 through 4.
- 6. **Do** Job Sheet 2, “Take Oil Sample, and Change Oil and Filter(s).”
- 7. **Stop** Have instructor evaluate your performance and if the evaluation is satisfactory, continue to Step 8. If the evaluation is not satisfactory, study the procedure outlined in Job Sheet 2 and repeat Step 6.
- 8. **Study** Expanded Checklist, “Engine Off” Tasks 5 through 25.
- 9. **Do** Job Sheet 3, “Inspect Engine Coolant Level and Condition.”
- 10. **Stop** Have instructor evaluate your performance and if the evaluation is satisfactory, continue to Step 10. If the evaluation is not satisfactory, study the procedure outlined in Job Sheet 3 and repeat Step 9.
- 11. **Do** Job Sheet 4, “Pressure Test Coolant System and Radiator Cap.”

Learning Activities Sheet

- 12. **Stop** Have instructor evaluate your performance and if the evaluation is satisfactory, continue to Step 13. If the evaluation is not satisfactory, study the procedure outlined in Job Sheet 4 and repeat Step 11.
- 13. **Study** Expanded Checklist, “Engine Off” Tasks 26 through 28 and “Engine On” Tasks 1 through 4.
- 14. **Do** Job Sheet 5, “Make a Charging System Output Test; Determine Needed Repairs.”
- 15. **Stop** Have instructor evaluate your performance and if the evaluation is satisfactory, continue to Step 16. If the evaluation is not satisfactory, study the procedure outlined in Job Sheet 5 and repeat Step 14.
- 16. **Check** With instructor for any additional assignments to be completed.
- 17. **Study** Expanded Checklist, “Engine On” Tasks 5 through 9.
- 18. **Do** Job Sheet 6, “Perform an Engine Compartment Inspection.”
- 19. **Stop** Have instructor evaluate your performance and if the evaluation is satisfactory, continue to Step 20. If the evaluation is not satisfactory, study the procedure outlined in Job Sheet 6 and repeat Step 18.
- 20. **Stop** Have instructor evaluate your unit performance. If the evaluation is satisfactory, proceed to next learning activities sheet. If evaluation is not satisfactory, ask instructor for further instructions.

*Permission to duplicate this form is granted.

Engine Compartment Inspection

Inspection Code: ✓ - OK o - Follow-up Needed x - Adjusted, Service/Repaired NA - Not Applicable		
ENGINE COMPARTMENT INSPECTION		
Inspection Item	Code	Init.
Engine Off		
Check belts, tensioners, and pulleys; check and adjust belt tension		
Check engine oil level; check engine for oil, coolant, and fuel leaks		
Take an engine oil sample		
Change engine oil and filters; visually check oil for coolant or fuel contamination; inspect and clean magnetic drain plugs		
Check electrical wiring, routing, and hold-down clamps, including Engine Control Module/Powertrain Control Module (ECM/PCM)		
Check throttle linkages and return springs		
Check starter, mounting, and connections		
Check alternator, mountings, wiring and wiring routing		
Check windshield washer fluid level; fill as necessary		
Check master cylinder fluid level and condition		
Check hydraulic clutch slave and master cylinders, lines, fittings, and hoses, if applicable		
Check power brake booster(s), hoses, and check/control valves		
Change power steering fluid and filter		
Check power steering pump, mounting, and hoses for leaks, condition, and routing; check fluid level		
Check steering gear for leaks and secure mounting		
Check steering shaft U-joints, pinch bolts, splines, pitman arm-to-steering sector shaft, tie rod ends, linkage, and linkage-assist power steering cylinders		
Check A/C condenser and lines for condition and visible leaks; check mountings		
Check A/C compressor and lines for condition and visible leaks; check mountings		
Check fuel pump and fuel line mountings		
Check water separator/fuel heater; replace fuel filter(s); prime and bleed fuel system		
Service or replace air filter as needed; check and reset air filter restriction indicator		
Check turbocharger for leaks; check mountings and connections		
Check radiator (including air flow restriction, leaks, and damage) and mountings		
Service coolant filter/conditioner		
Check coolant recovery system		
Check coolant hoses and clamps		
Check coolant for contamination, supplemental coolant additives (SCA) concentration, and protection level (freeze point)		
Pressure test cooling system and radiator cap		
Check fan assembly and shroud		
Check air system for leaks (brakes applied)		
Check air system for leaks (brakes released)		
Check tilt cab hydraulic pump, lines, and cylinders for leakage; inspect safety devices; service as needed		

Abbreviated Checklist

Inspection Code: ✓ - OK o - Follow-up Needed x - Adjusted, Service/Repaired NA - Not Applicable		
ENGINE COMPARTMENT INSPECTION		
Inspection Item	Code	Init.
Engine On		
Check engine for oil, coolant, air, and fuel leaks		
Check air induction system: piping, charge air cooler, hoses, clamps, and mounting; check for air restrictions and leaks		
Check transmission oil level, type, and condition (automatic transmissions)		
Check/record alternator current and voltage output (alternator current/voltage output tests)		
Check A/C system condition and operation; check A/C monitoring system, if applicable		
Check operation of engine/exhaust brake		
Check operation of fan clutch		
Check HVAC air inlet filters and ducts; service as needed		

Coolant Concentration _____ Protection Level (freeze point) _____

Alternator Current Output _____ Alternator Voltage Output _____

Engine Compartment Inspection

Objective Sheet

**Unit
Objective**

After completing this unit, the student should be able to compete an engine compartment inspection. The student should demonstrate these competencies by completing Job Sheet 6.

**Specific
Objectives**

After completing this unit, the student should be able to:

1. Inspect and adjust drive belts and tensioners. (Job Sheet 1)
2. Take oil sample and change oil and filter(s). (Job Sheet 2)
3. Inspect engine coolant level and condition. (Job Sheet 3)
4. Pressure test coolant system and radiator cap. (Job Sheet 4)
5. Make a charging system output test; determine needed repairs. (Job Sheet 5)
6. Perform an engine compartment inspection. (Job Sheet 6)

Engine Compartment Inspection

Engine Compartment Expanded Checklist

Task 1

Engine Off

Check belts, tensioners, and pulleys

a. Belts

1) Check belts for:

- Cracks
- Glazing
- Jagged or streaked sidewall
- Tensile breaks in the cord body
- Uneven ribs on serpentine belts

Figure 1



Glazing



Tensile Break



Separating Layers



Uneven Ribs



Streaked Sidewalls



Cracks

- ##### 2) Check that belts ride slightly above pulley, not down into pulley (pulley may be worn)

Note: Worn out pulleys will wear belts out quickly; the belts may appear to have stretched.

Expanded Checklist

b. Tensioners

- 1) Check that belt tensioners are holding tension on the belt

Note: If a vehicle has an auto tensioner and the belt is loose, the belt must be replaced. They cannot be adjusted.

c. Pulleys

- 1) Check that pulleys do not have excessive play or wobble
- 2) Check that pulleys are aligned
- 3) Check pulleys for foreign objects

Task 2

Check engine oil

Note: Always clean around the dipstick with a clean rag before removing the dipstick

- a. Check that oil is at the proper level
- b. Check dipstick for signs of coolant and fuel contamination

Task 3

Check engine for oil, coolant, and fuel leaks

- a. Check the entire engine compartment for any visible signs of leaks, focusing on seals, gaskets, hoses, filters, and drain plugs

Note: Sometimes it's hard to determine where leaking fluids are coming from. Once fluids get into moving parts, they may be sprayed all over the engine compartment.

Task 4

Change engine oil and filters, inspect and clean magnetic drain plugs, and take an oil sample

- a. Change engine oil and filters; inspect and clean magnetic drain plugs
 - 1) Start and warm the vehicle to operating temperature
 - 2) Drain the oil and check the magnetic drain plug for contamination

Note: Evidence of metal shavings or other contamination on the magnetic drain plug could indicate problems within the engine.

- 3) Replace the oil filter
- 4) Refill with oil

- b. Take an oil sample

Note: Oil samples should be taken from oil midway through the draining.

Expanded Checklist

Task 5

Check electrical wiring, routing, and hold-down clamps; including Engine Control Module/Powertrain Control Module (ECM/PCM)

- a. Wiring
 - 1) Check that wiring is clear of moving parts
 - 2) Check that wiring is clear of heat producing sources (engine, etc.)
 - 3) Check that wiring is not pinched
 - 4) Check that wire insulators are not cracked, chaffed, or charred
 - 5) Check that wires are not rubbing against other wiring
- b. Hold-down clamps
 - 1) Check for missing hold-downs
 - 2) Check all hold-downs for secure attachment
 - 3) Check that hold-downs do not pinch the wiring
- c. Engine and Powertrain Control Modules
 - 1) Check that all sensor wires are no closer than 6" to hot surfaces

Note: If any wires are closer than 6" and cannot be rerouted, make sure they are protected by heat shields.
 - 2) Check all wiring and connectors on computer units

Task 6

Check throttle linkages and return springs

- a. Check that throttle linkages do not bind when applied
- b. Check that return springs are not broken and have retained their "springiness"

Task 7

Check starter mounting and connections

- a. Check that the starter is securely mounted
- b. Check that all electrical connections are tight and that wiring not rubbing or chaffing

Task 8

Check alternator mounting, wiring, and wire routing

- a. Check that the alternator is mounted securely
- b. Check that all electrical connections are tight and not corroded
- c. Check that electrical wiring is not rubbing or chaffing

Expanded Checklist

Task 9

Check windshield washer fluid

- a. Check that windshield washer fluid container is filled to the proper level

Task 10

Check hydraulic brake master cylinder fluid level and condition

- a. Check fluid level and condition in master cylinder. Add as necessary

Note: When adding brake fluid, use only brake fluids approved for that application.

- b. Check for fluid leaks

Task 11

Check hydraulic clutch slave and master cylinders

- a. Check hydraulic clutch slave fluid level and condition
- b. Check for fluid leaks on master and slave cylinder
- c. Check for proper routing and mounting of lines and fittings
- d. Check lines, hoses and fittings for leaks

Task 12

Check power brake booster(s), hoses, and check/control valves

- a. Check for secure mounting
- b. Check power booster(s) for external leaks
- c. Check control valve for external leaks
- d. Check all lines and hoses for leaks or kinks

Task 13

Check power steering fluid and filter

Figure 2—9-Quart Power Steering Reservoir, 3-Line

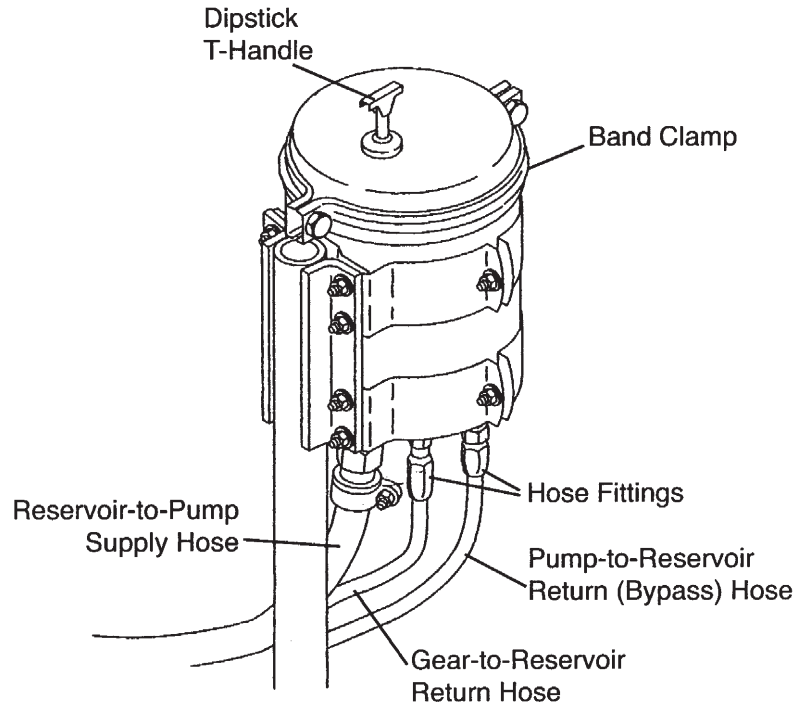

Courtesy of Freightliner LLC

- a. Check fluid level in power fluid reservoir

Note: Always clean around the dipstick with a clean rag before removing the dipstick

- 1) Add fluid as necessary

Note: Fill with only approved, clean fluid. Do not mix fluid types.

- 2) Check for leaks if fluid level is low

- b. Check power steering filter located in the reservoir; clean or replace as necessary

Task 14

Check power steering pump, mounting, and hoses for leaks, condition, and routing

- a. Check for fluid leaks around pump seals and fittings
- b. Check lines and hoses for leaks
- c. Check that lines and hoses are routed correctly and not rubbing other components
- d. Check that pump is securely mounted

Expanded Checklist

Task 15

Check steering gear for leaks and secure mounting

Figure 3—Ross Model 503 Manual Steering

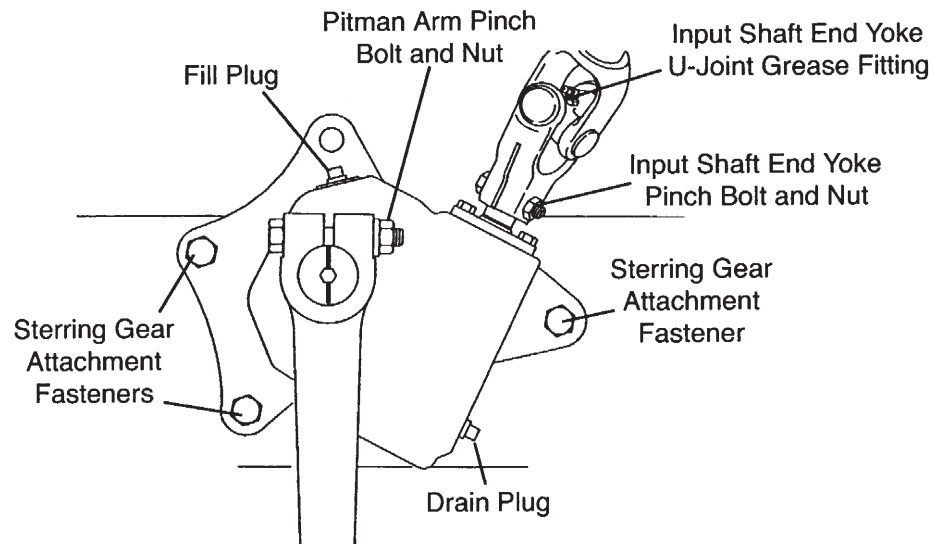

Courtesy of Freightliner LLC

- a. Check all fittings and seams for seepage or leakage
- b. Check input and output shafts for any leakage
- c. Check that mounting hardware is present and secure
- d. Check for cracks or other damage to the gear mounting areas

Task 16

Check steering shaft U-joints, pinch bolts, splines, pitman arm-to-steering sector shaft, tie rod ends, linkage, and linkage-assist power steering cylinders

- a. Pitman arm-to-steering sector shaft
 - 1) Check mounting of Pitman arm-to-steering gear output shaft for looseness
 - 2) Check that the splines on the Pitman arm and steering output shaft align and are tight
 - 3) Check for excessive play in the steering gear output shaft
- b. Steering shaft U-joints
 - 1) Check all steering shaft U-joints for excessive side and rotational play, and for secure attachment to steering shafts
 - 2) Check pinch bolts at the steering shaft

- c. Tie rod ends and drag links
 - 1) Check tie rod ends for excessive axial play (in/out of joint)
 - 2) Check drag link joints for excessive axial play (in/out of joint)
 - 3) Check that the threaded portion of the tie-rod end assembly is inserted into the cross-tube for adequate clamping.

Figure 4—Tie-Rod end Adjustment

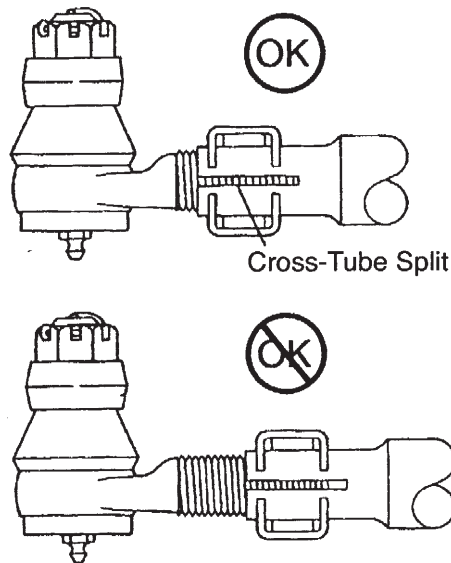

Note: Pinch bolt not shown to provide clarity.

Courtesy of Freightliner LLC

- d. Linkage assist power steering cylinders
 - 1) Check for secure attachment
 - 2) Check for leaks at fittings, hoses, and piston seals

Task 17

Check A/C condenser/compressor and lines for mounting, condition, and leaks

- a. Check the front side of the condenser for debris that might cause an airflow restriction
- b. Check that condenser is mounted tightly
- c. Check condenser lines for condition and leaks
- d. Check compressor for:
 - 1) Broken brackets
 - 2) Loose or missing bolts
 - 3) Alignment of belt and pulleys

Expanded Checklist

- 4) Condition of refrigerant hoses and for leaks
- 5) Dust caps on all service ports
- 6) Mounting and condition of condenser

Task 18

Check fuel pump and fuel line mountings

- a. Check that fuel pump mounts are secure
- b. Check that fuel line mounts are secure

Note: Loose pump or line mounts may fail from the vibration of the engine and road if not secure.

Task 19

Check water separator/fuel heater

Figure 5—Fuel Separator

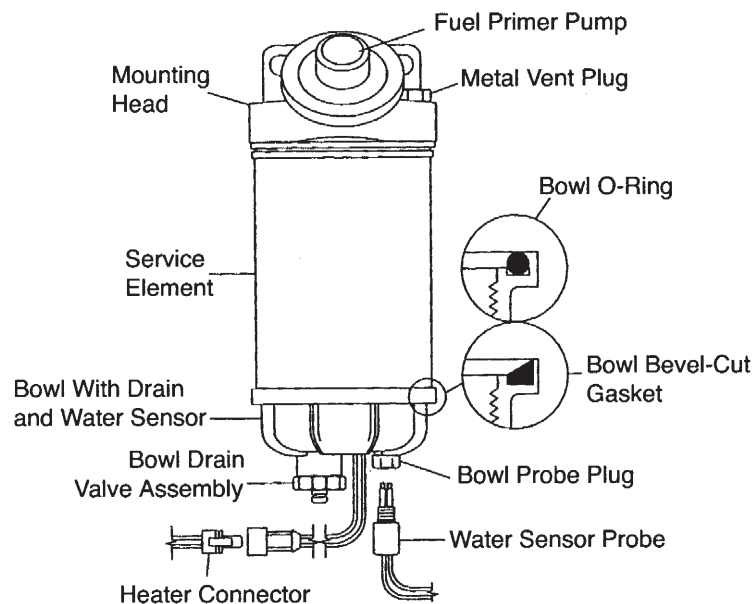

Courtesy of Freightliner LLC

- a. Check water separator and drain off excess water
- b. Check that fuel heater functions properly
- c. Replace fuel filter(s) according to the service manual.
- d. Prime and bleed fuel system according to the service manual.

Task 20

Check air filter

- a. Replace filter as required
- b. Check reading on the filter minder
- c. Reset air filter restriction indicator to zero

Expanded Checklist

Task 21	Check turbocharger for leaks; check mountings and connections <ul style="list-style-type: none">a. Check turbocharger visually for leaksb. Check mounting for securityc. Check charge air hoses and pipes
Task 22	Check radiator; service coolant filter/conditioner <ul style="list-style-type: none">a. Check radiator visually for leaks, damage, air flow restrictions (debris)b. Check that radiator is securely mountedc. Check coolant filter according to the service manual.
Task 23	Check coolant recovery system, and coolant hoses and clamps <ul style="list-style-type: none">a. Check recovery system for holes and proper mountingb. Check that the cap is securec. Check radiator hoses for leaks and cracksd. Check clamps for tightness
Task 24	Check coolant for contamination, additive concentration, and protection levels <ul style="list-style-type: none">a. Contamination<ul style="list-style-type: none">1) Check that there are no contaminants such as oil, rust, or debris present in the coolantb. Supplemental Coolant Additives (SCA)<ul style="list-style-type: none">1) Check coolant for proper inhibition either by test strip or titration method and record your reading on the checklist.c. Protection level (freeze point)<ul style="list-style-type: none">1) Check protection level using a refractometer and record your reading on the checklist. <p>Note: Protection level should be between -25°F and -35°F. If the system has the correct protection level but additional coolant is needed, use a 50-50 solution to top off the system.</p>
Task 25	Pressure test cooling system and radiator cap <ul style="list-style-type: none">a. Pressure test cooling system and radiator cap to insure correct pressure in the system

Expanded Checklist

Task 26

Check fan assembly and shroud

- Check fan shroud condition and mounting
- Check blade assembly for cracks
- Grasp fan blades and check for excessive play in the shaft
- Check for adequate clearance between all moving parts

Task 27

Check air supply system

- Check air system for leaks with brakes applied
- Check air system for leaks with brakes released.

Task 28

Check tilt cab system

- Check tilt cab hydraulic pump operation

Note: Make sure there is adequate clearance in front of the cab before activating the cab tilt system.

- Check tilt cab system hydraulic lines and cylinder(s) for leaks and damage
- Check safety device for operation

Figure 6

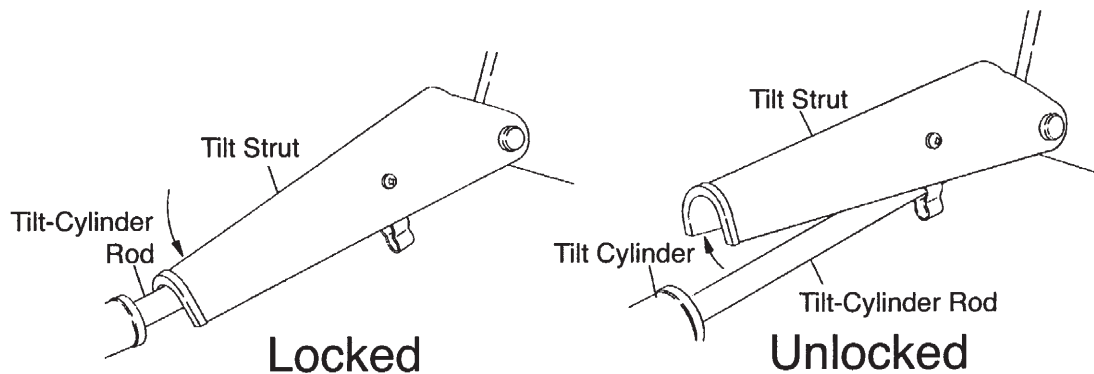

Courtesy of Freightliner LLC

- Check oil level and service as required

Engine On

Task 1

Check engine for oil, coolant, air, and fuel leaks

- Check all oil, coolant, air, and fuel lines for leaks

Task 2

Check air induction system

- Check charge air cooler for leaks
- Check piping for leaks

Expanded Checklist

	<ul style="list-style-type: none">c. Check all hoses for leaks and restrictionsd. Check for cracked or broken mountings and brackets
Task 3	<p>Check transmission oil level, type, and condition (automatic transmissions)</p> <ul style="list-style-type: none">a. Check that transmission oil is at the “full” mark on the dipstick <p>Note: Always clean around the dipstick with a clean rag before removing the dipstick.</p> <ul style="list-style-type: none">b. Check oil for presence of water (milky color) or metallic particles (silver sheen)c. Check that the oil does not smell burntd. Check for the recommended type of oil before adding oil to the transmission
Task 4	<p>Check/record alternator current and voltage output</p> <ul style="list-style-type: none">a. Check and record alternator current outputb. Check and record alternator voltage output
Task 5	<p>Check air conditioning system</p> <ul style="list-style-type: none">a. Check that all controls function properlyb. Check for proper cooling in the cabc. Check for proper level of refrigerant
Task 6	<p>Check operation of engine/exhaust brake</p> <ul style="list-style-type: none">a. Exhaust brake<ol style="list-style-type: none">1) Build air pressure to at least 85 psi2) With the engine at idle, activate the exhaust brake with the switch on the dash3) The brake should exhaust releasing the brake’s air supply system<p>Note: Accelerating the engine should release the brake.</p>b. Engine brake<ol style="list-style-type: none">1) Use the procedures contained in the appropriate service manual.

Expanded Checklist

Task 7

Check operation of fan clutch

- a. Check that the fan clutch engages at the correct temperature

Note: All fan clutches will engage when the engine temperature reaches a predetermined temperature which is above the thermostat opening temperature.

- b. Check that the fan clutch engages when the A/C system is engaged

Task 8

Check HVAC inlet filters and ducts

- a. Check that HVAC inlet filters are clean
- b. Check that the inlet ducts are clear of debris

Task 9

Check exhaust system for leaks, proper routing and damaged or missing components; check mountings for looseness and damage

- a. Mounting and damaged/missing components
 - 1) Check muffler(s) for secure mounting to vehicle, pipes, or exhaust stacks
 - 2) Check for missing fasteners on exhaust pipes and mufflers
 - 3) Check supports for excessive rust or cracks
 - 4) Check muffler for holes, dents, or other damage
 - 5) Check for missing components (such as mufflers)
- b. Leaks and routing
 1. Check pipes and mufflers for any sign of leaks

Note: It is not permissible for the exhaust system to be leaking at a point forward of, or directly below, the driver/sleeper compartment.

2. Check that the exhaust outlet is aft or above of any part of the vehicle designed to be occupied
3. Check that the exhaust system does not rub or contact any other objects

Note: No part of the exhaust system shall be positioned in a location that could result in burning, charring, or damaging the electrical wiring, fuel supply, or any combustible part of the vehicle.